

1 MATTHEW R. WALSH
2 19197 GOLDEN VALLEY RD #333
3 SANTA CLARITA, CA 91387
4 (661) 644-0012

5 Plaintiff In Pro Per,

6 **UNITED STATES DISTRICT COURT**
7 **CENTRAL DISTRICT OF CALIFORNIA**

MATTHEW R. WALSH
Plaintiff In Pro Per,

vs.

ROKOKO ELECTRONICS
(AND DOES 1 THROUGH 50,
INCLUSIVE)
Defendant

Case No.: 2:25-CV-05340-ODW-RAO

Before: Hon. Otis D. Wright II
Courtroom 5D

**EXPERT REPORT and Testimony of
Matthew R. Walsh**

8
9 **1. Expert Identification**

10 I am Matthew R. Walsh, I submit this report as the primary expert witness in
11 this case. While I am the Plaintiff in this matter appearing pro se, I am competently
12 providing this document as a wholly neutral expert witness report. This report is
13 based solely on the evidence before me and the factual basis surrounding that
14 evidence.

15 It should be stated that I am not the expert witness in this action *because I*
16 *am the Plaintiff*, but rather, I am the Plaintiff in this action because I am the most

17 qualified person to litigate this matter due to it's highly technical nature. From past
18 experience, hiring an attorney simply adds a layer of dilution between myself and
19 the Court which I believe slows or prohibits the technical flow of information in
20 this case; therefore I must act as both the litigator and the Plaintiff. This report is
21 submitted wholly as a neutral forensic investigator; and purely of technical
22 analyses and finding devoid of argument. The evidence has all been authenticated
23 under penalty of perjury and provided to the Defendant prior to the authoring of
24 this document.

25
26 I submit this declaration in support of the Plaintiff, Matthew R. Walsh's action
27 against Defendant, Rokoko Electronics.

28
29 **2. Qualifications**

30 I have over 26 years of experience in computer programming, software
31 engineering and architecture design and development; and in computer security. I
32 am a digital investigator and forensic analyst presently retained by law firms
33 including but not limited to Harder Stonerock, LLP; and have been an expert in
34 high profile cybersecurity/computer hacking/CFAA adjacent-Court cases dating to
35 2008.

36 As part of my daily profession, I am a professional software engineer
37 systems architect where I solely engineer and program highly complex systems
38 (700,000+ lines of code) using more than twenty (20) programming and scripting
39 languages for both the private and government sector – including LA County and
40 the Department of Homeland Security. I am wholly self-employed by my own
41 software company which produces international industrial software and automation
42 systems, established in 2007.

43 I have authored published security tools beginning at age 14 that have been
44 recognized by Microsoft, McAfee, Trend Micro, Symantec, Sophos, and others,
45 and my work has been featured in multiple magazines. I became a full time
46 professional programmer at 15 and enrolled in evening college for Computer
47 Science at 16 years old which I achieved a 4.0gpa. My professional career since
48 then has experienced no gaps and I have worked on hundreds of projects.

49 Further, I am highly experienced in video game/film production. I am a
50 published video game developer with titles(s) licensed by Nintendo, Sony and
51 Valve. I own and operate Winteryear Studios, a game, film, 3D, VR, animation
52 studio. I am qualified in all aspects of production including expert knowledge of
53 motion capture, facial recognition and deep fake technology.

54 Lastly, I have experience in commercial-scale microcontroller-based (ARM,
55 ESP, Arduino, Basic Stamp, etc.) hardware and software development, including

56 the authoring of custom protocols for communication and execution stacks and
57 firmware development.

58

59 **3. Assignment and Scope**

60 The causation chain of why I became involved is quite simple.

61

62 Hardware Failed → Company Refused Repair → Engineer Investigates

63

64 As Plaintiff's Rokoko hardware no longer worked and Rokoko had refused
65 parts, repair and replacement for nearly seven months; I chose in April of 2025 to
66 use my technical capabilities to self-diagnose the equipment hoping to restore it's
67 functionality and continue development of Plaintiff's video game The Next World.
68 Instead, during my analysis, I discovered numerous issues which are the sole basis
69 of this lawsuit and highly detailed within this document.

70

71 **4. Materials Reviewed**

72 This report is based on **(a)** Rokoko Studio, it's underlying communication
73 layers, encrypted communications, programmatic requests/responses/replies to
74 their servers and cloud application layers and system logs. **(b)** Rokoko Smartsuit,
75 it's firmware, sensors, system logs, hardware components, communications with

76 my own computer and Rokoko’s own internal developer tools (c) Rokoko’s format
77 of animation data files (d) Real-life events which occurred and in relation to these
78 technologies (e) Rokoko’s own statements.

79 All materials are present in produced discovery in which the Defendant has
80 possession of nearly 3,750 pages of evidence. Throughout this document, it will be
81 referenced by the bates stamp which corresponds to that evidence (e.g.,
82 WALSH000123).

83

84

85 **5. Technical Background**

86 The Rokoko motion capture system is based on a number of interdependent
87 components, both physical and software.

88 1. (**“The Textile”**) - a clothing garment which houses most of the hardware. It
89 is specific clothing designed with channels to hide the sensors and the Trunk
90 wiring for each limb.

91 2. (**“The Hub”**) – a standalone computer system mounted on the users lower
92 back which interprets the sensor data and transmits it to the Rokoko Studio
93 software using TCP/IP over WiFi.

94 a. The Hub is powered by what appears to be a low power Redpine
95 RS9113 ARM Cortex semiconductor. The Hub is complete with

96 WiFi, USB and Device I/O for connection to the sensors as the
97 Redpine chip comes standard with those stacks integrated (Wi-Fi, BT,
98 BLE, ZigBee and Thread).

99 b. The sensors branch from the hub using six wiring trunks (aka “wire
100 harnesses”), one for each limb and one for the head/neck.

101 c. Once a trunk reaches where a sensor is located, the trunk stops,
102 connects to the sensor, then on the opposite end another (“Wire”)
103 trunk continues downward until it reaches another sensor and
104 continues the pattern.

105 d. The Hub has a core software structure containing the firmware,
106 bootloader, unique_id (in this format: xx-xx-xx-xx), usb_api_version,
107 wifi_api_version, bt_api_version (Bluetooth), serial_number (12 byte
108 length), latitude, longitude, earth_mag_field_x (magnetic),
109 earth_mag_field_y, and gravity.

110 3. **“Sensors”** – the sensors track inertial and kinetic movement changes and
111 report them back to The Hub at fixed polling intervals (~100 fps).

112 i. The Code references the following sensor data vectors:
113 First_buffer1, First_buffer2 First_buffer3, First_buffer4,
114 signature, version (format: 00.00.00-00), [**boot_status**],

115 boot_version, is_calibrated, epoch, calibrationID, id_unique,
116 reserved, SerialNumber (byte format: xx-xx-xx-xx)

117 b. Rokoko states the sensors have four LED states:

118 i. No color - Booted up properly.

119 ii. Red – Sensor is not working properly.

120 iii. Blue – Communication with The Hub cannot be established
121 (faulty cable)

122 **iv. Blinking Green – Sensors in bootloader mode;** the most
123 important status to recognize for the matter at hand.

124 4. (“**SmartGloves**”) – Textile gloves which are placed onto the users hands
125 and connected by USB to a battery source. They contain their own miniature
126 onboard computer which acts the same as The Hub and have smaller sensors
127 for finger joints. The gloves do **not** physically connect to The suit’s Hub, nor
128 do they use ‘The Wires’.

129 5. (“**The Firmware**”) – The operating software for The Hub, The Smartgloves
130 and the Sensors. It is a single .BIN file with a RKKsFO (**RoKoKo San**
131 **FranciscO**) binary signature which is a large, multi-container bucket with an
132 enveloped header, trailer and payload, which carries about six separate
133 firmware files. The firmware is downloaded programmatically by Rokoko

134 Studio from the URL (<https://cdn.rokoko.com/firmware/>) and then installed
135 onto the SmartSuit and SmartGloves hardware.

- 136 6. According to analyses of Rokoko’s own source code, a single firmware
137 package holds multiple upgrade targets: (a) UpgradeHubFirmware (b)
138 UpgradeSensorFirmware (c) UpgradeModulesFirmware (d)
139 UpgradeBootUpgrader (e) UpgradeBootloader (f) UpgradeSensorFromBoot

140 a. The firmware extracts a number of individual firmware payloads. The
141 overall structure references a key, SerialNumber and Status; while the
142 payloads are: [SmartGlovesFirmware, HubFirmware,
143 SensorFirmware, RedPineFirmware, BootLoaderUpgrade and
144 BootLoader] indicating full ecosystem hardware modification upon
145 firmware update.

146 b. The firmware update system contains default hardcoded firmware
147 files; assumably the lowest allowed baseline versions such as
148 `smartsuit_pro_sensor_firmware_v2.0.1-18-release.sfs`,
149 `smartsuit_pro_hub_firmware_v2.6.3-81-release.sfh`,
150 `smartsuit_pro_hub_firmware_v2.5.4-950-release.sfh`,
151 `smartsuit_pro_sensor_firmware_v2.0.0-1277-release.sfs`

- 152 7. (“**Rokoko Studio**”) or **Rokoko Studio (“Legacy”)** – The software which
153 runs on a users computer and connects to Rokoko Hardware (up to 10

154 SmartSuit's at a time) and servers. It is responsible for (a) managing the
155 scene; actors and equipment (b) receiving and recording the animation data
156 from each users' suit (c) translating the raw vector and inertial data into
157 spatial 3d animation data (d) providing visualization of that data and
158 allowing it to be refined by the user (e) enabling data import and export
159 functionality and (f) handling device health, diagnostics and firmware
160 updates.

161 8. (“**Animation Data**”) or (“Animation”) or (“Intellectual Property”) – The
162 movements from the Sensors are read by The Hub and transferred to Rokoko
163 Studio Software which then translates them into spatial 3D movement at a
164 fixed framerate interval; capturing the actors movements almost perfectly
165 and recording them.

166 a. The Animation Data for Legacy is stored in a .srec file with an
167 accompanying .srec.meta file. The .srec file has a binary signature of
168 “RKK!SR”.

169 b. Most importantly, **these file(s) clearly contain CMI** including the 12-
170 byte serial numbers of each actors Hub, the actors name, height,
171 biometric measurements and the serial numbers of each Sensor.

172 9. **Rokoko (“Teams”)** – A paid, subscription based, opt-in service which
173 collects user animation data and stores it in an online cloud platform on
174 Rokoko’s U.S. based servers.

175 10. (“**System Files**”) – Rokoko software uses a number of file formats,
176 Recordings (.srec), Project Container (.ssproj), Profile (.ssprof), Project File
177 (.ss), SmartSuit Firmware (.sfh), Hub Firmware (.sfh), Bootloader Firmware
178 (.sbh), Sensor Firmware (.sfs), WiFi Configuration (.wifi)

179 11. (“**Rokoko Servers**”) – the remote internet-reachable servers that Rokoko
180 utilizes in their operations. All U.S. based. This is where Rokoko Studio
181 communicates with Rokoko’s internal software, api layers, databases and
182 stores account information, customer information, animation data, users
183 intellectual property and more.

184 a. ping.rokoko.com [18.65.3.76] amazon San Francisco

185 i. This appears to be a user tracking / phone home system.

186 b. cdn-studio.rokoko.com [3.169.252.38] amazon San Fran.

187 i. This appears to be Rokoko Studio’s main operational server
188 which hosts various downloads (such as Rokoko Studio,
189 firmware, etc.)

190 c. fw-api.rokoko.com [13.226.225.121] amazon San Francisco

191 i. This appears to be the firmware API server which handles
192 firmware requests, matching and downloads.

193 d. rmp-gql-public.rokoko.com [3.167.192.77] amazon San Francisco

194 i. This appears to be Rokoko’s GraphQL server for bidirectional
195 data transfer.

196 e. id.rokoko.com [13.52.115.166] amazon San Francisco

197 i. This appears to be Rokoko’s user authentication server.

198 f. rokoko-id-new.netlify.app [54.215.62.21] amazon San Francisco

199 i. This appears to be a third party API building tool.

200 g. rmp-team-gql.rokoko.com [3.167.212.100] amazon San Fran.

201 i. This appears to be Rokoko ‘Teams’ GraphQL server

202 h. cdn-scene.rokoko.com [18.164.174.97] amazon L.A

203 i. This appears to be Rokoko’s remote scene image rendering
204 platform (turns 3d into 2d images)

205 12.(“**Rokoko Database**”) – The database system and query language which
206 runs on Rokoko’s servers and acts as a data storage and intermediary query
207 language between Rokoko Studio and Rokoko’s Servers and Database. The
208 query language used is Facebook/Meta’s GraphQL for data, as well as
209 WebSocket PUT requests for file transfer. The GraphQL language and

210 WebSocket PUT requests match and authenticate the described and visual
211 evidence used throughout this action.

212

213 **6. Motion Capture Production Pipeline**

214 The animations at issue were produced through a very standard workflow
215 pipeline involving motion capture recording, data processing, export to animation
216 files, and integration into the game engine.

217

218 Screenplay → Live Acting → Actor Movement → Sensors → Hub →

219 Network → Computer → Rokoko Studio → Animation File → **(Rokoko**

220 **Harvesting Data Secretly)** → Human Animator for Manual Cleanup →

221 Retargeting for Game Character → Video Game → Sequencer or Animation

222 Blueprint → Complete

223

224 **Illustration:**

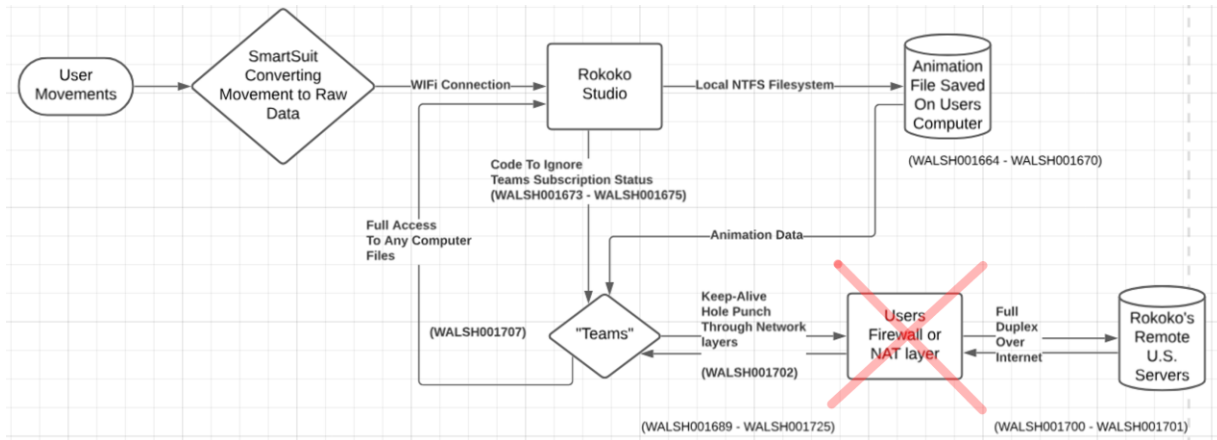

225

226 **7. Firmware Behavior and System Failure**

227 Analysis of the firmware updates and system behavior demonstrates that
 228 Rokoko developed and then released a very specific firmware update, which the
 229 developer notes indicate **they were knowledgeable of the fact that it would**
 230 **permanently destroy gen1 hardware right around Rokoko’s End of Life for**
 231 **that unit (September, 2024).**

232 **First**, Rokoko authored and thereby created The Firmware which had a 319
 233 kilobyte filesize. **Second**, Rokoko published The Firmware to their servers on
 234 January, 9, 2024 as version 7.2.3.0-94. **Third**, At a pricey unknown time in 2024,
 235 Rokoko set the release flag to “1” which in their system which is a standard
 236 boolean signal to tell one or more users’ Rokoko Studio software that it is time to
 237 download and install The Firmware.

238 Most importantly, the developer release note as hosted by Rokoko’s servers
 239 stated: *“Important: This breaks compatibility with older hub + glove*

240 [Firmwares]”. As of April 2025, when much of this investigation was conducted,
241 this appeared to be the most recent / last released firmware by Rokoko for the Gen
242 1 SmartSuit Pro, such as Plaintiffs’; indicating it was, in fact, the operative
243 firmware which affected the Plaintiff’s equipment.

244 Of significant import, Rokoko Studio’s source code shows the default,
245 lowest sensor firmware allowed, provided and auto-installed is
246 “smartsuit_pro_sensor_firmware_v2.0.1-18-release.sfs”; however, in Plaintiff’s
247 logs and diagnostic reports post-upgrade – the sensor firmware version is much
248 lower than the minimum viable baseline -- v2.0.0.0.

249 It should be noted further that the developer notes openly indicate that it
250 only “*breaks compatibility*” with “[*older*] hub + glove”. It is well within held
251 technical knowledge – and further explained here in in plain English -- that the
252 firmware targets both the old hardware and the new at the same time without
253 distinction. The Firmware clearly states it would disrupt the operation of only
254 Plaintiff’s Gen 1 hardware, while their newer Gen 2 hardware would continue
255 operationally.

256

257 **Illustration:**

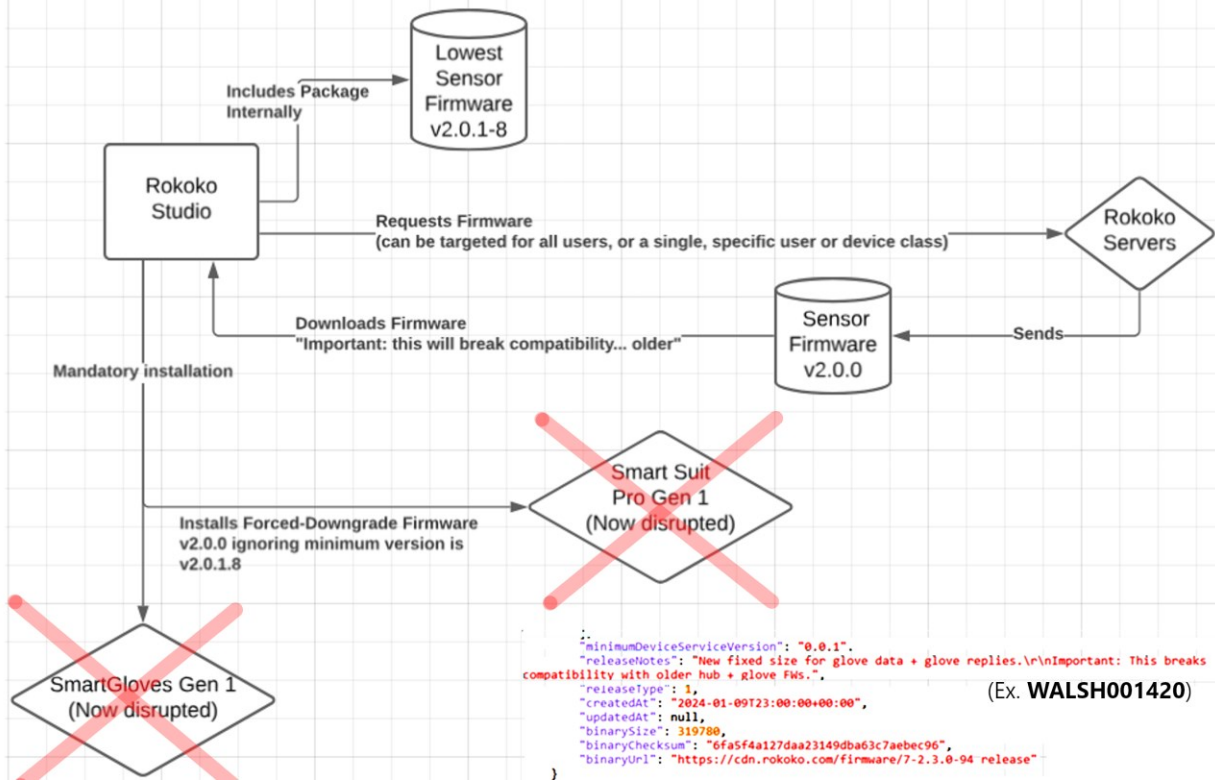

258

259

260 8. Supporting Technical Evidence

261

262

263

264

265

266

267

This conclusion is supported by system logs, developer records, network captures, software behavior observations, Defendants’ source code, and related diagnostic materials along with the Defendants’ public statements. The tools used are industry standard and household names to those who engage in this field of work. The tools, methodologies and procedures meet the standards of Daubert, as I myself do as well.

268
269
270
271
272
273
274
275
276
277
278
279
280
281
282
283
284
285
286
287

1. **Firmware and Hardware Failures:**
(Bates No. WALSH001420 - WALSH001468)
2. **The First Disruptive Firmware Release and Rollback** - In 2023, Rokoko released a firmware update which crippled both SmartSuit units and the SmartGloves. The prior day all equipment worked. After The Firmware update, neither did. As of 2026, Rokoko’s website presently states that The Firmware had in fact, caused these very issues.
3. Rokoko at this time, as is demonstrated by the evidence, admitted directly to the Plaintiff that the firmware had failed (3/20/2023).
4. The suits remained wholly disabled pending Rokoko customer service intervention which appears to have taken 30 to 60 days for each engagement.
5. Rokoko requested log files from the SmartSuit to determine the cause of error and required remote support sessions in which Rokoko interacted with Plaintiff’s computer system directly.
6. Rokoko support placed their internal customer support tools on Plaintiff’s computer. Once they were finished, they right clicked the tools and sent them to the Recycle Bin, but did not permanently delete them.
7. Rokoko support determined the suit had physical damage with ‘wires’, and sold replacements. The ‘wires’, once again, are wire harness/trunk extensions which go from sensor to sensor, daisy chaining them.

288 8. **Manufactured Conflict of Fact** - It should be noted, that the LED states on
289 the sensors, contrary to Rokoko's own support documents were blinking
290 green; as reported to Rokoko multiple times. This indicated the sensors were
291 stuck in bootloader mode **not having communication issues with the hub**
292 **or wiring** (which would instead would cause the sensor LED's to illuminate
293 Blue).

294 9. Upon changing the wires, the suits remained non-functional, the sensors still
295 in blinking green LED bootloader mode. Rokoko's suggestion was to send
296 the suits in for repair. As Plaintiff was deep in production at the time, other
297 animation solutions were utilized.

298 10. **Self-Repair of the Suits** - Upon realizing Rokoko's official developer tools
299 were still on Plaintiff's computer, they were removed from the Recycle Bin
300 and used to re-flash the SmartSuit's to an earlier firmware file. One suit
301 began working again, the other remained non-functional as it would not
302 accept a new firmware file. **This confirmed the firmware had been the**
303 **issue, not the wiring.**

304 11. There were hundreds of required scenes which were single-person only;
305 having only one suit at this time was of no consequence.

306 **12.Final Suit-Destroying Firmware** - Months later, Rokoko issued a
307 mandatory firmware update. This firmware immediately caused the Rokoko
308 Smartsuit Hub and Sensors to not operate.

- 309 a. Within Rokoko code (FirmwareUpdateModal.cs), a Boolean is
310 present `DISABLE_FIRMWARE_UPDATES` which by default is set
311 to true; indicating Rokoko retains the power to remotely trigger these
312 updates and make them mandatory, despite their public website
313 stating all updates are optional.

314 13.The lights on the sensors showed the sensors were receiving power,
315 transmitting and receiving data, and were not in a definitive fail state.

316 14.Log files show the hub began reporting technical failures and further that all
317 sensors could not be detected, yet, were reporting errors.

318 15.Analyses of the sensors in both Rokoko Studio and on the sensor LED's
319 showed they were in mixed boot states. Despite this, Rokoko stated their
320 interpretation of the logs stated the Wires indicated failure, however, the
321 logs are plain text and obvious in language and they clearly indicate sensor
322 and hub failures. Further, the SmartGloves as well no longer worked, which
323 was telling – as the gloves do **not** connect to The Hub, nor do they use
324 'Wires' for connectivity.

325 16. According to the evidence, Rokoko denied parts, repair or replacement for a
326 period of seven months (September 2024 to April 2025). Finally in about
327 March, 2025; Rokoko once again requested log files stating the log files they
328 had were ‘too old’. Plaintiff complied, and once again, Rokoko stated the log
329 file indicates wiring issues. The log files, in fact, did not show wiring issues
330 – they showed sensor and hub failures. Precisely matching Rokoko’s
331 developer note warning.

332 **17. Forensic Analyses of Rokoko Systems:**

333 18. In April, 2025; I began forensically investigating the Rokoko Studio
334 software. To do so, I needed to intercept their communications and data.

335 **a. Protocol Discovery**

336 b. I first used the industry standard tool WireShark, a packet sniffer, to
337 detect and monitor the traffic coming and going from Plaintiff’s
338 computer. By default, WireShark returns all communications that
339 occur from all programs. I continued filtering and isolating the traffic
340 until it was narrowed to only communications between Plaintiff’s
341 computer and Rokoko’s servers.

342 **c. Rerouting Communication Traffic, Bypassing Encryption**

343 d. Now knowing the IP addresses, ports, protocols, encryption methods
344 and endpoints, I then used a tool called Proxifier which allows for

345 select programs to have their communications temporarily redirected
346 to a different endpoint.

347 e. The communications between Plaintiff's computer and Rokoko's
348 servers was clearly occurring over TLS (Transport Security Layer)
349 encrypted by SSL (Secure Socket Layer) communicating via HTTPS
350 (Hyper Text Transport Protocol; port 443)). To overcome this
351 encrypted communication stack, I installed a new Root Certificate
352 Authority (CA) ("Fake SSL certificate") into Plaintiff's system's
353 "Trusted Root Certification Authorities" store. This creates a secure
354 communication layer that *appears* secure, however, as there are no
355 unknowns, all data that flows can be easily intercepted and monitored.

356 f. Instead of allowing the communications of Rokoko Studio to go
357 directly to Rokoko's servers in a 1:1 exchange, I used Proxifier to
358 instead route the traffic from Rokoko Studio to MITMProxy to
359 Rokoko's Servers.

360 **g. Passive Man-In-The-Middle Attack**

361 h. I then routed the Proxifier data to MITMproxy, a widely used security
362 monitoring tool.

363 i. Using this stack of tools, I then performed a MITM (Man-In-The-
364 Middle-Attack) which is essentially where there is normally two

365 endpoints: Rokoko Studio (local on Plaintiff's computer) to Rokoko
366 Servers (remote/internet); but instead, now, there are three endpoints:
367 Rokoko Studio (my computer) to MITMproxy (my computer) then to
368 Rokoko's Servers (remote/internet).

369 **19. Legality**

370 It is important to state that while these methods may appear unscrupulous,
371 the CFAA (Computer Fraud and Abuse Act) as well as international data
372 and privacy and computer hacking laws only apply to situations where the
373 interceptor is not an authorized party to the communications. Here, there is
374 no lack of privilege to the communication as Plaintiff is an intended
375 recipient of the communications as an authorized user of the Rokoko Studio
376 software. All communications are two-party between the Plaintiff and
377 Rokoko, of course. As a matter of fact -- due to how the internet works -- all
378 communications are inherently intercepted potentially dozens or hundreds of
379 times and passively monitored before reaching their destination. Further, all
380 interception was only performed on software and communications contained
381 on Plaintiff's own computer system. As one of two parties to the
382 communication, Plaintiff has a lawful right to be a party that
383 communication. (Van Buren v. United States, 593 US 374 (2021))

384

385 **Illustration:**

Usage of Rokoko Studio Typically

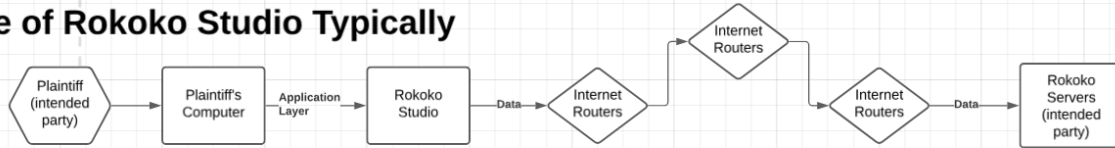

Investigation Usage

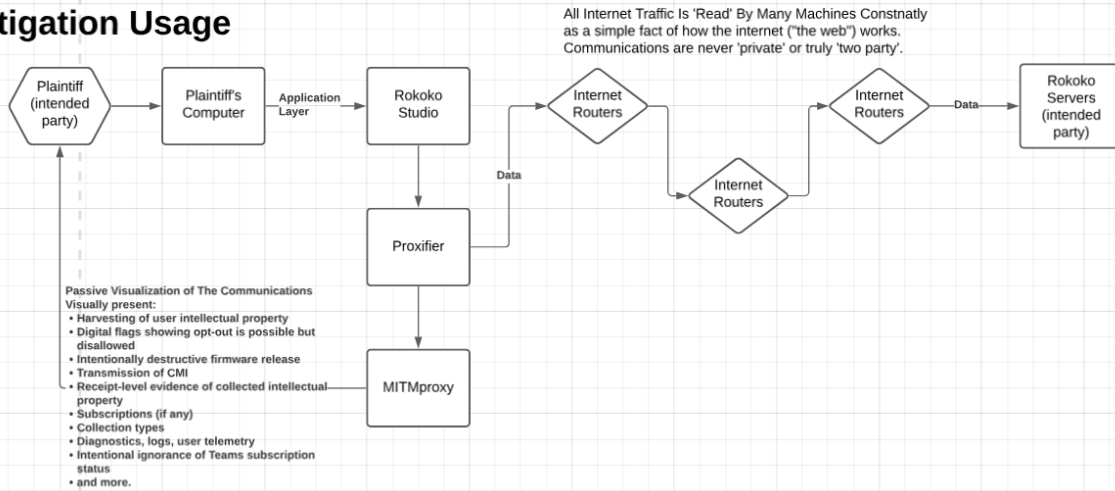

386

387 **20. Analysis and Production of Evidence**

388 **(Bates No. WALSH002407 - WALSH002415)**

389 **(Bates No. WALSH001664 - WALSH001725)**

390 21. The first step to bringing a claim for DMCA violations was to assess

391 whether the .srec Animation files contained CMI or not. They were opened

392 in HxD, an industry standard Hex Editor (binary file & memory

393 viewer/forensic analyses tool) widely used for more than 20 years.

394 a. The animation files did in fact contain CMI (WALSH001664 -
395 WALSH001670) including but not limited to biometrics, author name,
396 actor names, unique ID's, device serial numbers, etc.

397 22. Analyses of the underlying communications provided most of the underlying
398 evidentiary matter in this action:

399 a. **Rokoko Intentionally Released Destructive Firmware** – The
400 intercepted communications from Rokoko's server provided a list of
401 firmware packages which have been released in JSON format. The
402 most recent firmware contained a developer note which said
403 *“Important: will break compatibility with older glove + hub*
404 *[[firmwares]”*. This firmware was released to the public despite this
405 knowledge.

406 i. It is worth noting that the wording here is specific, it does not
407 break compatibility with *newer* gen 2 devices, only *older* gen 1
408 devices. Meaning, gen 2 will be the only operable devices and
409 gen 2 will be 'destroyed' upon release.

410 b. **Rokoko consistently received live diagnostics and knew of the**
411 **firmware's damage** – Rokoko did not need logs, nor customer
412 support sessions or access to Plaintiff's computer. They were always

413 made aware, instantly what issues the SmartSuit hub and sensors were
414 experiencing as detailed below.

415 **c. Rokoko knew the sensors were malfunctioning and the firmware**
416 **was installed** – The live diagnostics clearly indicated the firmware
417 version of the sensors and The Hub. The diagnostics also clearly
418 stated the sensors had failed, were stuck in mixed boot states and
419 could not start. Despite this, they continually suggested ‘wires’ for
420 two years. This JSON diagnostic envelope is sent live to Rokoko
421 consistently:

```
422  
423 .. {"device": "smartsuit_pro",  
424 "device_serial_number": "R8PZA06KVJYU" ....  
425 "successfully_initialized": false, "device_sensor_firmware": "2.0.0-  
426 r", "has_error": true,  
427 "error_type": "sensors_in_mixed_boot_states"}, ...
```

428
429 i. It should be noted, the sensor firmware version is NOT the
430 same as the firmware version which Studio downloads. As
431 stated prior, there are multiple firmware packages inside the

432 single .bin file which has it's own version release number.

433

434 d. **Rokoko harvested my intellectual property** – Plaintiff's intellectual
435 property was immediately transferred to Rokoko servers over
436 WebSocket PUT requests.

437 e. Creating new animations or even copying existing ones to new names
438 such as 'WILLROKOKOTAKETHIS' and 'PLEASEDONTSYNC'
439 immediately caused those animations to be taken by Rokoko, who
440 then programmatically provided a confirmation of collection, storage
441 and receipt.

442 **23. Analyses of Rokoko's Source Code**

443 24. I further investigated the Rokoko Studio software by obtaining the Source
444 Code to the software and it's underlying systems and dependencies.

445 a. Rokoko Studio utilizes Unity (a video game engine).

446 b. As Unity's programming language of choice is C#, that means that all
447 software written in C# is compiled to MSIL (**M**icrosoft **S**ymbolic
448 **I**ntermediate **L**anguage)

449 c. I used industry standard applications .NET Reflector and JetBrains
450 DotPeek to load the various Rokoko Studio assemblies, which
451 revealed mostly unobfuscated source code.

452 i. **LEGALITY:** It should be noted that accessing MSIL code is
453 not actually decompilation nor is it reverse-engineering. The
454 code is stored in essentially comparable plain-text format (as
455 symbolic bytecode) and is interpreted by the JIT (**J**ust **I**n **T**ime)
456 Compiler (the executable package which in the code is
457 packaged with) to create a running application. Rokoko did
458 nothing to protect or hide the visibility of their source code.

- 459 1. They did not compile to Native Code (bypassing the JIT
460 compiler and MSIL)
- 461 2. They did not obfuscate their code (a simple, even free
462 and standard programmatic scrambling process)
- 463 3. Rokoko simply provided their code in a format which
464 could both be executed and used *and read in it's original*
465 *source code format.*

466 d. The source code shows a number of issues:

- 467 i. **Forced Consent of Terms** - Rokoko forces that the user has
468 accepted the Terms & Conditions (EULA) even in instances
469 where they have not.
- 470 ii. **Username/Password Bypass Backdoor** - Rokoko Studio
471 contains a backdoor written by Menalos (an ex-employee from

472 three years ago in Greece) who wrote an authentication bypass
473 to allow him (or anyone with knowledge) to log into Rokoko
474 Studio without the users username or password and then have
475 unbridled and untethered access to Rokoko Studio which
476 contains intellectual property, animation data, user account
477 information and so forth.

478 **iii. Harvesting Intellectual Property By Ignoring User**

479 **Preference** - The 'Teams' system ignores whether a 'Teams'
480 subscription is in place and instead forces collection of
481 intellectual property, regardless of subscription, payment or
482 user consent. In Plaintiff's case: Plaintiff never signed up for
483 Teams, never added a collaborator, a credit card, was never
484 billed, did not approve and yet the Rokoko Studio software was
485 programmed to ignore that and still collect the intellectual
486 property.

487

488
489
490
491
492
493
494
495
496
497
498
499
500
501
502
503
504
505
506

iv. The intercepted communications confirmed all of this. In this truncated section of intercepted data, it can be seen that there are no members, no billing, no viewers, yet skip_asset_sync is false; meaning – “take animations anyways”

```
“myTeamsWithLicenses” {  
“billing_admins:null”, “members:null”,  
“viewers:null”, “plan:STARTER”,  
“offline_days:1”, “skip_asset_sync:false”  
}
```

Even more notable, is that the software code itself only allows DisableSynching if a users subscription plan allows it. This can be evidenced on Rokoko’s website where they charge for an Enterprise plan that does not take or use intellectual property:

```
DisableSynching = (current user’s) “planEntitlements”
```

- 507 v. The intellectual property, when harvested is taken over
508 WebSockets and transferred to Rokoko's servers.
- 509 vi. **Harvested Intellectual Property Targets a 'Public'**
510 **Directory** – The code shows that the intellectual property is
511 targeted to a folder called /Public with no further designation of
512 project, user, etc.
- 513 vii. **Exceeding Access To Users' Computer Systems And**
514 **Bypassing Network Security Layers - Strangely, the 'Teams'**
515 code also creates a webserver on the users computer.
- 516 viii. The webserver binds to * (all adapters/IP addresses/networks)
517 and creates a listener.
- 518 ix. It further uses MQTT (an "uninterruptable" lightweight
519 messaging protocol developed by IBM) along with a hole-
520 punch mechanism (creates a hole through a multi-NAT
521 (Network Address Translation) network so that Rokoko can
522 connect inward and bypass security restrictions like firewalls).
- 523 x. The WebServer operates in a Default Realm of 'SECRET
524 AREA'.

525 xi. This system also included a keep-alive, which is a timed
526 outbound connection “pulse” at a fixed interval whose goal is to
527 never allow the hole-punch (or pinhole) to close.

528 1. It is worth noting, for a system which uses WebSockets
529 to PUSH data to Rokoko, it is concerning that Rokoko
530 creates a server and a security bypassing pathway
531 **inward, from Rokoko into the users computer.**

532 **xii. Rokoko Claims GDPR Compliance, Has No European**
533 **Servers** – Rokoko Studio code confirms all of Rokoko’s
534 operational servers are in America (Downtown Los Angeles),
535 AWS in Virginia and Washington). Yet, Rokoko claims on
536 their website they comply with GDPR privacy and data
537 regulations; and even holds many government contracts with
538 the Danish government in which they state they comply with
539 GDPR.

540 **xiii. Overreaching File I/O Exposed To Backdoor Access** – The
541 webserver that Rokoko Studio initiates gives anyone who can
542 connect to it full access to read any file on the computer with no
543 restrictions or safeguards:

544
545 public byte[] GetFile(string path) {
546 return File.ReadAllBytes(path);
547 }
548
549

550 Additional, there are registered events for expected inbound
551 activity: OnGet, OnPost, OnPut, OnDelete, OnPatch,
552 OnConnect

553
554 The server spins up a thread (essentially a program within a
555 program which does not interfere with the main system) and is
556 actively listening for inbound connections:

557
558 this._listener.Start();
559 this._receiveThread = new Thread(receiveRequest);
560

561 xiv. Rokoko Studio already transmits Animation data to Rokoko
562 servers using WebSocket-based file PUT's; which is full duplex
563 communication. Therefore, as the file sharing mechanisms
564 already existed in place, I could find no legitimate use for this
565 functionality, which bypasses all network layers and firewalls

566 to provide access to users computer systems available to the
567 outside world.

568
569 **9. Beyond Technical Evidence**

570 1. Rokoko’s website and materials make clear, plaintext express admissions to
571 the allegations set forth in this report.

572 a. 2022 pre-investor pitch deck outlines plan to harvest, collect, resell,
573 sublicense and use users’ intellectual property (Bates No.

574 WALSH001727- WALSH001736)

575 b. The Website openly states that firmware updates have caused the
576 above described issues and as of 2026 they are still requiring users to
577 “contact Support for help to restore the sensors” and that “we’re
578 working on getting this properly restorable from within Studio” (Bates
579 No. WALSH001446)

580 c. Claims of GDPR despite U.S.-only servers for collection and storage
581 (*Bates No. WALSH001676, WALSH001700 - WALSH001701*)

582 d. Dataset made from users I.P. (*Bates No. WALSH001672*)

583 e. Policy and code force user reconnection and ‘synching’ (Bates No.
584 WALSH001673 - WALSH001675); ‘Enterprise’ payment model
585 required to prevent harvesting of Animation data (WALSH001737)

- 586 f. Animation I.P. will be collected, CMI stripped, resold, sublicensed
587 *(Bates No. WALSH001680 , WALSH001682, WALSH001692-*
588 *WALSH001693)*
- 589 g. Live website counter of collected user animations (Bates No.
590 WALSH001690) updated daily.
- 591 h. Sublicensing of users I.P will occur (WALSH001691)
- 592 i. Users Animation data will be used to train Artificial Intelligence
593 Models, of which Rokoko also sells a subscription to (Bates No.
594 WALSH000003 - WALSH000008)
- 595 j. Video evidence from Rokoko’s software shows harvesting of
596 intellectual property in real-time (WALSH001679, WALSH001689,
597 WALSH001699)
- 598 k. Terms & Conditions from 2020 – March 29, 2025 contain no license
599 whatsoever for Rokoko to resell or sublicense users intellectual
600 property. March 30, 2025 imposed sweeping retroactive terms back-
601 claiming license (Bates No. WALSH002454 - WALSH002503) these
602 agreements are packaged part and parcel with the software installation
603 media (Bates No. WALSH002449 - WALSH002448).

604

605 **10. Reproducibility of Results**

606 1. The investigative procedures and analyses described in this report are
607 reproducible by any qualified technical expert using the same commercially
608 available tools and hardware/software environment. The tools referenced in
609 this report -- including Wireshark, Proxifier, MITMproxy, HxD, JetBrains
610 DotPeek, and .NET Reflector -- are standard industry tools widely used in
611 cybersecurity, software engineering, and digital forensic analysis.

612 2. The following procedures may be repeated by an independent expert to
613 reproduce the findings described herein:

614 3. Firmware and Hardware Failure Analysis:

615 a. A Rokoko SmartSuit Pro (Gen1) system running the firmware version
616 identified in this report may be tested by installing the referenced
617 firmware update package and observing device initialization behavior
618 through Rokoko Studio diagnostics and sensor LED states. System
619 logs generated by Rokoko Studio will reflect the same error
620 conditions described herein by the two devices analyzed, including
621 sensors entering mixed boot states and initialization failures.

622 4. Firmware Rollback Verification:

623 a. Using Rokoko's internal support tools referenced in the evidence, the
624 SmartSuit hub and sensors may be flashed to an earlier firmware
625 version. Where hardware has not been irreversibly affected, this

626 rollback restores operational status of the suit, confirming that the
627 failure condition was introduced by firmware rather than wiring or
628 sensor hardware defects.

629 5. Network Communication Observation

- 630 a. By running Rokoko Studio or Rokoko Legacy on a local system and
631 monitoring network traffic using Wireshark, an expert may identify
632 the same network endpoints, protocols, and communication patterns
633 between Rokoko Studio and Rokoko servers as described in this
634 report.

635 6. Intercepted Communication Analysis

- 636 a. By routing Rokoko Studio and Legacy network traffic through a local
637 proxy using Proxifier and intercepting the traffic using MITMproxy
638 with a locally installed trusted root certificate authority, an expert may
639 observe the same diagnostic telemetry, firmware package listings, and
640 animation upload communications described herein. It should be
641 noted that Rokoko Studio and Legacy must be used extensively across
642 all of it's features to achieve the same depth of evidentiary matter.

643 7. Animation File CMI Verification

- 644 a. Opening Rokoko .srec animation files using any hex editor such as
645 HxD will reveal embedded metadata fields containing Copyright

646 Management Information (CMI), including device identifiers, actor
647 metadata, and serial numbers consistent with the examples referenced
648 in this report.

649 **8. Software Behavior and Source Code Inspection**

- 650 a. Loading Rokoko Studio assemblies into .NET analysis tools such as
651 JetBrains DotPeek or .NET Reflector allows inspection of the MSIL
652 contained within the assemblies, revealing the same programmatic
653 behaviors and systems described in this report, including firmware
654 update handling, data synchronization logic, and network
655 communication structures.

- 656 9. Each of these procedures relies only on publicly available tools, the Rokoko
657 software distributed to users, and the Rokoko hardware devices themselves.
658 No proprietary Rokoko internal systems were accessed during this
659 investigation. As such, a qualified expert with access to the same hardware
660 and software environment will be able to reproduce the observations and
661 results described herein unless Rokoko has taken post-litigation steps to
662 alter, secure or prevent such access.

663
664 **11. Compensation**

665 I am the Plaintiff in this matter. As such, I have received no compensation
666 for my testimony or expert opinion.

667

668 **12. Conclusion**

669 1. Based on my analysis, it is of my expert analysis and opinion that:

670 a. Rokoko released a firmware update, which the developer notes clearly
671 stated would ‘break’ gen 1 hardware. Once released, it rendered the
672 motion capture system unusable and destroyed my Rokoko SmartSuit
673 and Gloves and all subcomponents therein.

674 b. In Rokoko Studio versions since at least 2022, Rokoko has harvested
675 users intellectual property.

676 c. In all versions of the Rokoko software from at least January 1, 2020 to
677 March 30, 2025 (including the March 29, 2025 version); all included
678 license agreements shipped as part and parcel of the software never
679 contained any license rights to users intellectual property.

680 d. As my hardware was destroyed in 2024, it is temporally impossible
681 that I could consent to any such terms.

682 e. The conclusions as listed appear to be wholly intentional by design.

683

684 **13. Authentication of Evidence**

- 685 a. The evidentiary information relied upon in this report was generated,
686 collected, and organized through an automated system designed authored
687 and implemented by the undersigned. The system employs defined and
688 repeatable processes for data acquisition, preservation, and output, including
689 integrity checks at each stage. As the undersigned has full knowledge of the
690 inner-workings of that system, these processes are sufficient to support a
691 finding that the resulting records are what they are claimed to be, consistent
692 with Federal Rule of Evidence 901(b)(9).
- 693 b. The records comprising the evidentiary dataset exhibit distinctive
694 characteristics, including consistent formatting, metadata, source identifiers,
695 and internal relationships between files. These characteristics were analyzed
696 for internal consistency across the dataset and are sufficient to support a
697 finding of authenticity pursuant to Federal Rule of Evidence 901(b)(4).
- 698 c. The evidence relied upon in this report was further evaluated through
699 comparative analysis, including re-testing and reproduction of results using
700 independent methods. These comparisons yielded consistent outputs across
701 formats, including demonstrative reproductions such as recorded testing
702 procedures. This process supports authentication under Federal Rule of
703 Evidence 901(b)(3).

704 d. The undersigned has personal knowledge of the methods used to collect,
705 process, and analyze the evidence, including direct involvement in the
706 acquisition and validation of the records. This knowledge supports
707 authentication under Federal Rule of Evidence 901(b)(1).

708 e. All evidence referenced herein has been maintained in its original or
709 forensically preserved form, without material alteration. To the extent any
710 format conversions were necessary for analysis or presentation, such
711 processes preserved the substantive content of the records.

712

713 **14. Peer Reviewed Materials for Verification of Expert Assessments**

714 Please note: none of these materials were used to conduct the tests herein, nor were
715 they relied upon for knowledge. They are being submitted post-authoring of this
716 document simply to establish that the undersigned's own methods and personal
717 knowledge are echoed in ISO certified, peer reviewed and published materials and
718 scientific journals. All journals are ISO 9001:2008 certified) written by the
719 International Research Journal of Engineering and Technology (IRJET).

- 720 1. **NAT Traversal and Hole Punching** - A thorough explanation of Hole
721 punching across TCP, UDP and ICMP protocols has been provided to the
722 Defendants in discovery.
- 723 2. **WebSocket Protocol for Real-Time Data Transfer** – A thorough
724 explanation of real-time data transfers across WebSockets (how Defendant's
725 allegedly transmitted intellectual property) has been provided to the
726 Defendants in discovery.

- 727 3. **Cyber Attacks and Different Types (including MITM used here)** - A
728 thorough explanation of various cyber attacks (which are only illegal /
729 maleficent based on intent, and in fact, are just a regular part of daily
730 software engineering and debugging processes).
- 731 4. **Research Paper on Machine Learning and its application-** A thorough
732 explanation of machine learning and it's applications (one of the reasons for
733 harvesting of intellectual property by the Defendants). This journal has been
734 provided to the Defendants in discovery.
- 735 5. **An Artifact-Driven Framework for Detecting File Wiping and**
736 **Timestamp Manipulation in NTFS Systems** - A thorough explanation of
737 using the HxD tool (which Plaintiff used to analyze CMI within animation
738 files) and how it is used forensically. This journal has been provided to the
739 Defendants in discovery.
- 740 6.
- 741

742 I declare under penalty of perjury under the laws of the United States of America
743 that the foregoing is true and correct.

744

745 Executed March 8, 2026

746

747 

Matthew R. Walsh
Plaintiff In Pro Per